



GT氣壓齒輪式震動器 GT Series Pneumatic Gear Vibrator

產品說明/Feature

● 產品特點 Product Features

震動大小可根據壓壓調整,可馬上起動.停止.速度快.低噪音.振動力大.安全

Vibration intensity can be adjusted based on air pressure, can immediately start, stop, fast, low-noise, vibration force, security.

● 產品應用 Application

物料輸送.振動篩選.料斗振動.幫助包裝填充.鑄造砂模振動

Feed material conveyor, vibrating screening, vibrating hopper, to help fill packaging, foundry sand mold vibration.

● 工作原理 Works

齒輪內安裝偏心銅配重.空氣充入進氣孔沖擊齒輪產生推力使齒輪旋轉.旋轉時偏心配重的離心力產生震動.齒輪油軸承帶動.低噪音

Copper eccentric gear installed counterweight impact ai intake charge into the gear thrust gear rotates, the eccentric rotation of the centrifugal weight with vibration, the gear driven by a bearing, low noise.

技術參數/Technical parameters

型號 Type	頻率 Frequency(V.P.M)			振動力 Vibration power(N)			空氣消耗量 Air consumption(/min)		
	0.2Mpa	0.4Mpa	0.6Mpa	0.2Mpa	0.4Mpa	0.6Mpa	0.2Mpa	0.4Mpa	0.6Mpa
GT-4	11500	12500	13500	130	165	210	30	40	50
GT-6	11500	12500	13500	130	165	210	30	40	50
GT-8	34850	42000	45500	980	2.100	2.800	46	80	112
GT-10	27500	35000	37500	840	1.390	2.400	46	80	112
GT-13	26000	30000	33000	1.400	2.440	3.730	120	200	290
GT-16	17000	21500	24000	1.220	2.090	3.160	120	200	290
GT-20	17000	20000	23000	2.170	4.040	5.520	185	325	455
GT-25	12000	15500	17000	2.120	3.510	5.070	185	325	455
GT-32	13000	14000	16000	3.380	5.430	7.540	330	530	745
GT-36	7800	10000	13000	3.300	5.000	7.150	330	530	745
GT-40	7500	8800	9500	4.350	7.350	9.850	408	428	680
GT-48	5800	7500	9700	4.950	7.750	10.600	408	428	680
GT-60	4758	6530	8515	5.700	9.800	11.150	505	600	920

外型尺寸/Dimensions

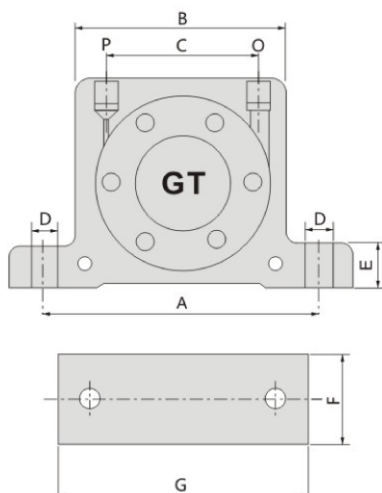

型號 Type	A	B	C	D	E	F	G	P/O	(mm)
									重量 Weight(g)
GT-4	56	40	20	6	10	28	70	1/8	280
GT-6	56	40	20	6	10	28	70	1/8	280
GT-8	68	50	28	7	12	35	86	1/8	280
GT-10	68	50	28	7	12	35	86	1/8	280
GT-13	90	65	39	9	16	43	113	1/4	610
GT-16	90	65	39	9	16	43	113	1/4	610
GT-20	104	82	56	9	17	56	128	1/4	1120
GT-25	104	82	56	9	17	56	128	1/4	1120
GT-32	130	103	76	11	21	73	160	3/8	2150
GT-36	130	103	76	11	21	73	160	3/8	2150
GT-40	152	122	85	18	27	80	194	3/8	3530
GT-48	152	122	85	18	27	80	194	3/8	3530
GT-60	195	140	96	21	30	95	240	1/2	5590